

Dear Racer,

Thank you for choosing the TVS Apache RTR 200 Fi4V with ABS.

The newest member of the Apache family now comes with Dual-Channel ABS for unmatched control on the track. Every feature on the Apache is honed on the race track to deliver the best in racing performance.

The motorcycle has a rich racing pedigree, with the Apache Series RTR winning 16 national championships in 2016 alone. As a proud owner of the TVS Apache RTR 200 Fi4V with ABS, you are now part of the two million strong TVS Racing family.

This manual explains the features and operations of your TVS Apache RTR 200 Fi4V with ABS. Please read it carefully and follow the instructions to enjoy the ultimate racing experience.

To prolong your journey on the TVS Apache RTR 200 Fi4V with ABS, we urge you to get your TVS Apache RTR 200 Fi4V with ABS services only at TVS Motor Company Authorised Distributor or Dealer / Authorised Service Centers.

Here's to your new lap on the Apache RTR 200 Fi4V with ABS.

TVS MOTOR COMPANY LIMITED

Always keep your Owner's Manual in the motorcycle and give it to the new owner if you ever transfer your TVS Apache RTR 200 Fi4V with ABS.

Take time to familiarize yourself with your TVS Apache RTR 200 Fi4V with ABS and its performance characteristics.

This Owner's Manual contains a host of useful information. Please take the time to read this manual before you ride your new TVS Apache RTR 200 Fi4V with ABS. Get familiarised with the operation of your motorcycle for maximum safety and pleasure. The better you know your vehicle, the more pleasure you will experience riding your new vehicle. Ensure that anyone else riding your TVS Apache RTR 200 Fi4V with ABS does the same.

All information, illustrations, photographs and specifications contained in this owner's manual are based on the latest product information available at the time of this publication. TVS Motor Company Limited may, however, incorporate modifications or improvements on its vehicles at any time without notice, and therefore, in such events it is possible that the relevant part of the owner's manual does not apply to your vehicle.

Prior permission of TVS Motor Company Limited is required for quoting, copying or reproducing any part of this owner's manual.

 Note

Accessories shown in the picture may not be part of the standard equipment.

Part Number :

Revision 0, July 2018

Operating this vehicle safely is an important responsibility of the rider. To help you make decisions on safety, we have provided necessary operating procedure and other information in this manual. This information alerts you on potential hazards that could hurt you or others. Since it is not possible to warn you about all the hazards associated with operating or maintaining the vehicle, you must use your own judgement.

You will find important safety information in following form in this manual. These words carry the following connotations:

Warning

*Disregarding this message might result in **injury to the rider or deadly accidents.***

Caution

*This message indicates special procedures or precautions to be followed to **avoid damage to the vehicle.***

Note

*This message provides further clarification for **clear understanding of any particular information.***

Running-in information	01
Antilock braking system	02
Safe riding tips	08
Know your TVS Apache RTR 200 Fi4V with ABS	12
Riding your TVS Apache RTR 200 Fi4V with ABS	33
Maintenance	39
Service record sheet	59
Technical specifications	62



The first 1000 km is a crucial part of your motorcycle. Proper running-in operation during this period helps in ensuring a **maximum life** and **smooth performance** of your motorcycle.

The reliability and performance of your motorcycle depends on the special care and restraint exercised during the running-in period. It is especially important that you avoid operating the engine in high speed (RPM), which could expose the engine parts to excessive stress. Recommended speed during the running-in is:

Maximum 50 km/h speed upto 750 km (vary the engine speed for better mating of parts).

The first service at 500 ~ 750 km is most important. During running-in period all the engine components and other parts will have set in. All adjustments to be restored, all fasteners to be tightened. Engine cum transmission oil to be replaced. Timely performance of the first service will ensure optimum service life and performance from the engine.

Caution

Replacing the engine cum transmission oil during first service is most important for better life of engine. Always use TVS TRU4 FULLY SYNTHETIC oil (SAE 10W30 API-SL, JASO MA2) or recommended equivalent oil for better performance and life.

*Since your motorcycle is fitted with Evaporative Emission Control System, **the motorcycle should not be laid on the floor during water wash.** Else it may lead to difficulty in starting and improper running of the motorcycle.*

Anti-Lock Brake System (ABS)

Your motorcycle is fitted with an Anti-lock braking system (ABS) which is designed to prevent skidding and help riders to maintain steering control during emergency-stopping situation in dry or wet roads, loose gravels etc.

How does ABS work?

When a rider applies the brakes continuously as he detects a dangerous obstacle in dry or wet roads, loose gravels etc. transmits an excessive brake force to the wheel. This excessive force may cause the wheel to stop spinning and leads to lose of road grip. With no firm contact between the tire's contact patch and the road surface, the bike becomes unstable and a crash is imminent.



ANTI-LOCK BRAKE SYSTEM



The slipping wheels on a riding surface results in losing control of whole motorcycle which usually occurs in fractions of a second. Restoring traction while keeping the bike balanced is only a result of luck, or extreme training, as is the case of professional stunt riders who drift. Preventing the wheels from slipping due to excessive braking force compensates losing control and help the rider to maneuver the vehicle and to avoid accidents.

So what the ABS does is actually limiting the braking force exerted by the rider by either squeezing the lever or pressing the brake pedal and keep the wheel spinning. Once the imminence of the locking (and therefore skidding) is avoided, the system re-applies the maximum braking force until the next skid is anticipated.

By limiting the max force of the braking maneuver, the ABS systems practically allow riders to use the greatest stopping force possible without locking the wheels.

How does the ABS understands the wheel locking?

The ABS uses continuous wheel speed monitoring system; wheel speed sensors and toner rings and a Hydraulic Electronic Control Unit (HECU).

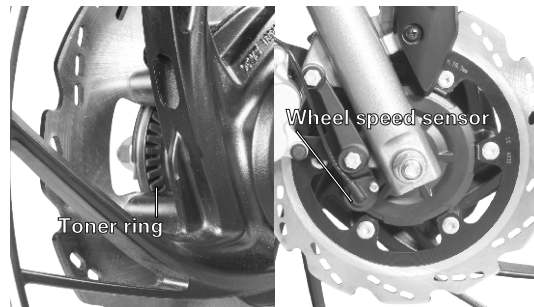

During normal operation the ABS works similar to a normal brake, but functions only when the wheel tends to lock up. The speed sensors fitted on both the wheels measures the rotational speed of the wheel, when the wheel speed reduces rapidly i.e. wheel tends to lock, the HECU modulates the pressure in the brake circuit and thereby prevents the wheel from locking.

How the irregular road surface affects the braking?

Humps and irregular surfaces of the road can cause the wheels to lose contact temporarily with the road surface; if this happens the braking force that can be transmitted to road surface is zero.

If the brakes are applied under these condition, the ABS has to reduce the braking force to ensure and maintain the directional stability *when the wheels regains its contact with the road surface. At this instant the ABS must reduce the traction, so that the wheels will continue to rotate under all imaginable circumstances, because this is the precondition for ensuring directional stability. As soon as the actual circumstances arises, the system reacts instantly and adjusts braking force accordingly to achieve optimum braking.*

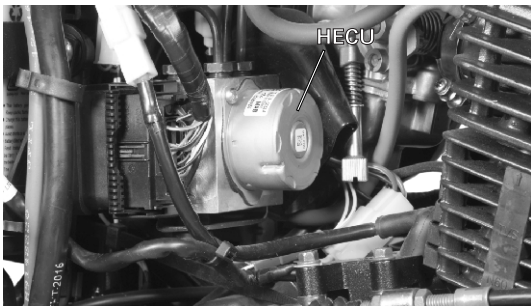

Why does brake pedal / lever pulsate during brake application?

Vehicles fitted with ABS uses the conventional brake system during normal operation. **But during hard stop the brake pedal / lever feels different, i.e., a rapid pulsation in the brake pedal / lever; This is absolutely normal.**

It is not necessary to have this pulsation feel every time the brake is applied. Pulsations are felt only during wheel locking tendency, occurs due to the modulation of pressure in the brake circuit by HECU. Pulsation means that the vehicle is in limit. This pulsation feel also depends on the road condition.

Rear wheel lift

Under very severe and sudden deceleration, however, under certain circumstances it is possible that the ABS unit fitted in your vehicle will be unable to prevent the rear wheel from lifting clear of the ground and flip over.

Severe braking can cause the rear wheel to lift off the ground. When you brake, bear in mind that ABS control cannot always be relied on to prevent the rear wheel from lifting clear of the ground.



Warning

The ABS can apply and release the pressure in the brake circuit much faster than that rider can do with brake pedal / lever to avoid wheel locking, so there is no need to pump the brake, it requires only continuous application.

The Apache RTR 200 Fi4V with ABS does an automatic self check every time the ignition switch is turned 'ON'. The ABS warning lamp provided at the speedometer console blinks and informs you that the ABS is under check.



This ABS warning lamp goes 'OFF' once the bike reaches 10 km/h speed and above, indicating that the ABS is working fine. If the warning lamp continuously 'ON' even after the vehicle crossing 10 km/h speed then ABS has an error and your bike should be taken to any of your nearest TVS Motor Company Authorised Distributor or Dealer / Authorised Service Center.

DO'S AND DON'T'S

Do's

- ◆ Check the ABS warning lamp for any warning before driving the vehicle.
- ◆ Apply both front and rear brake for better performance.
- ◆ Apply continuous brake in ABS mode for better performance. Do not pump.
- ◆ Perform the periodic maintenance as per the schedule.
- ◆ ABS should be serviced only at TVS Motor Company Authorised Distributor or Dealer / Authorised Service Center.
- ◆ Carefully remove the wheel during puncture / tyre replacement to prevent toner ring damage / bend.

- ◆ **Keep the wheel in such a way that the toner ring is facing upwards.**
- ◆ Always use recommended brake fluid. Use fresh, clean brake fluid.
- ◆ Use only the recommended make, type and size of tyre (ABS tuned with tyre specified by the TVS Motor Company).

Don't's

- ◆ Do not use **non-standard tyres.**
- ◆ Do not pump the brakes. Apply the brakes continuously
- ◆ Do not ignore any warning lamp on speedometer.
- ◆ Do not adjust the wheel speed sensor air gap your self.
- ◆ Do not run the engine and ride or rotate the rear wheel alone in gear with vehicle on centre stand, for drive chain lubrication, during water wash etc.,
- ◆ Do not attempt to correct the toner ring teeth by bending manually or by using any other mode.
- ◆ Do not use different toner ring.
- ◆ Do not insert any metallic parts near wheel speed sensor.

- ◆ Do not test the ABS on road!!, but use ABS (it is already tested).
- ◆ **Do not use non-genuine spares like pads, discs, tyres etc.**
- ◆ Do not try to service HECU or open to separate parts..

Warning

ABS only helps in improving the vehicle control. It is always good to remember not to exceed the physical limits of the vehicle stability. It is rider's responsibility to ride at a suitable speed, while taking care of conditions and road surface. ABS will not compensate for errors in the judgement or improper brake use in the various situation. ABS never eliminates the danger of falling while turning.

Hard braking during sharp cornering on slippery surface may lead to vehicle instability. Under such circumstances gradual braking is recommended.

Use of non-genuine brake pads, tyres, disc etc. leads to poor braking performance and unsafe riding conditions.

Warning

Do not ride the vehicle in conditions like wheelie, stoppie, on-stand engine revving in gear for chain lubrication and during water wash etc... for more than three minutes as it will result in ABS error and ABS warning lamp glowing continuously. In such cases, just switch 'OFF' and switch 'ON' the ignition key once. ABS warning lamp may glow continuously if any ABS error had occurred before.

This error gets cleared automatically and ABS warning lamp goes 'OFF' after riding the vehicle above 10 kph speed. If ABS warning lamp is still 'ON', then contact the nearest TVS Motor Company Authorised Distributor or Dealer / Authorised Service Center.

Note

Incase of ABS failure, the braking system will work like a non ABS braking system and provides normal stopping distance.

Note

This motorcycle is equipped with ABS and tubeless tyres. For repair or replacement please contact nearest TVS Motor Company Authorised Distributor or Dealer / Authorised Service Center.

As a general riding practice it is advisable to apply more front brake and less of rear brake.

Never open HECU on your own, it is a very sensitive part of ABS and needs to be handled only by the trained personnel. Contact your nearest TVS Motor Company Authorised Distributor or Dealer / Authorised Service Center.

SAFE RIDING RECOMMENDATIONS

Any two wheeler riding requires some precautions to be taken to ensure the safety of the rider, pillion rider and other road users. These precautions are:

Familiarise yourself with new TVS Apache RTR 200 Fi4V with ABS

Riding skill and your mechanical knowledge forms the foundation of safe riding practices. We suggest you to practice riding TVS Apache RTR 200 Fi4V with ABS in a low-traffic condition until you are thoroughly familiar with your vehicle and its controls. Remember practice makes you perfect.

Riding apparel

Loose, fancy clothing can be uncomfortable and unsafe when riding a two-wheeler. Choose good quality two wheeler riding apparel.

Know your limits

Ride within the boundaries of your own skill at all times. Knowing these limits and staying within them will help you avoid accidents.

Warning

Two wheeler safety starts with wearing a good quality helmet. One of the most serious injuries that can happen is a head injury. Always wear a good quality helmet that should fit your head comfortably and securely. You should also have good quality goggles to protect your eyes and help your vision.

To prevent or minimize accident, never consume alcohol or drugs before or during the operation of your vehicle. Even minimal consumption of these will affect the rider's ability to control the vehicle.

Posture

Proper vehicle riding starts with proper posture.

1. Keep your elbows relaxed and flexible.
2. Sit and adjust yourself on seat so that the arms and shoulders are relaxed.
3. Look widely instead of gazing at one point.
4. Keep the knees close to the fuel tank.

Cornering

When cornering, centrifugal force works in a direction perpendicular to the direction in which the vehicle is moving. Centrifugal force increases in proportion with speed and the radius of the corner.

During cornering, reduce speed so as to reduce the effects of centrifugal force. Avoid abrupt application of brake or sudden steering by all means.

Warning

One-hand riding is dangerous. Keep both hands firmly on the handle bar and both feet securely on the foot rest. Under no circumstances should both the hands be removed from the handle bar, as it is very dangerous.

Avoid use of mobile phones while riding as it could lead to fatal accident.

Do not downshift the gears in the midst of cornering. Slow down to a safe speed before negotiating a corner. If this is the first time that you are riding a vehicle of this type, we suggest that you practice on a safe, open area to thoroughly familiarise with the operation of the vehicle.

Braking

For safe riding, it is very important to master the braking techniques.

1. Close / release the throttle.
2. Hold the vehicle upright as you apply the brakes.
3. Progressive application of brakes is safer.
4. Never depress the clutch lever while braking at higher speeds.
5. **Apply both the brakes.**
6. Do not pump the brakes.
7. While riding down hills, cornering and wet roads close the throttle and down shift the gear to take advantage of gearbox and engine which acts as an additional brake. This will avoid the loss of control over the vehicle due to over speed.

Causes for poor braking

1. If the brake shoes / pads or drum / disc are worn out or if there is water or oil on them, sufficient friction does not develop and brakes do not work well.
2. Even when the brakes work normally, if the road surface is wet or the tyre surface is worn-out, tyres do not take a firm hold on the surface, increasing the stopping distance.

3. Approximately 60% braking effect is from front brake. **Non-usage of front brake causes poor braking.**

Warning

As the vehicle speed increases, the stopping distance also increases progressively. Be sure that, you have sufficient distance between you and the vehicle or obstruction ahead of you.

*Using only the front or rear brake is dangerous and can cause skidding and loss of control. **Apply both the brakes together and with great care on a wet road or other slippery surfaces.** Any abrupt braking on slippery or irregular roads can cause loss of rider control.*

ACCESSORY INSTALLATION AND SAFETY TIPS

Use extreme caution while selecting and installing the accessories for your motorcycle.

The addition of **unsuitable accessories can lead to unsafe operating conditions**. Your friendly Distributor / Dealer will assist you in selecting quality accessories and installing them correctly.

While selecting the accessories, make sure the accessories **should not obstruct lighting, steering, suspension level and ground clearance**. Please ensure that if the tank cover is used, it is not getting en-trapped between fuel tank and fuel tank cap.

Additional electrical equipments and controls should not exceed the specified electrical system load of the vehicle (capacity of battery and magneto).

EMISSION CONTROL

All the TVS motorcycles are tested in the factory for optimum fuel efficiency and lowest possible CO levels.

Do not disturb the fuel supply settings as this may lead to higher fuel consumption and also higher CO levels.

If the vehicle needs any adjustments, please consult nearest TVS Motor Company Authorised Distributor or Dealer / Authorised Service Center.

While adequate care is exercised at the factory to ensure that the emissions are within the limits, it is essential for the owner to always maintain the motorcycle in good condition by getting it periodically checked and serviced by TVS Motor Company Authorised Distributor or Dealer / Authorised Service Center so that the emission and fuel consumption levels are maintained as per norms.

Crankcase emission control system

The engine of new Apache RTR 200 Fi4V with ABS is equipped with a closed crankcase system to prevent discharging crankcase emissions into the atmosphere. Blow-by gas is returned to the combustion chamber through the air cleaner and the throttle body.

Evaporative Emission Control System

The Apache RTR 200 Fi4V with ABS is equipped with an evaporative emission control system which consists of a canister and associated piping. This system prevents the escape of fuel vapors from the fuel tank.

Warning

If there is any abnormal jerk, startability issue are felt in the vehicle or noise due to sudden escape of gas during opening of fuel tank cap, immediately report to the TVS Motor Company Authorised Distributor or Dealer / Authorised Service Center.

VEHICLE IDENTIFICATION NUMBER

The frame and engine serial numbers are the only means of identifying your vehicle from others of the same model and type. They are also required to assist your Dealer for ordering parts or referring to special information.



Frame serial number is engraved on the right side of the steering head tube as shown in the above figure.



Engine serial number is engraved on the left side crankcase assembly near cylinder block as shown in the above figure.

Frame number

--	--	--	--	--	--	--	--	--	--	--	--	--	--	--	--	--	--	--	--

Engine number

--	--	--	--	--	--	--	--	--	--	--	--	--	--	--	--	--	--	--	--

Control key number

--	--	--	--	--	--	--	--	--	--	--	--	--	--	--	--	--	--	--	--

Please fill the above boxes now for future reference



LOCATION OF PARTS - HANDLE BAR

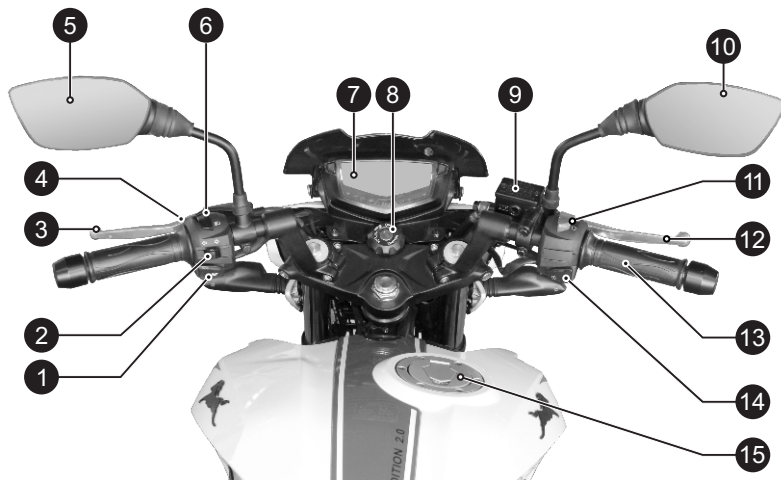

1. Horn switch
2. Turn signal lamp switch
3. Clutch lever
4. Pass by switch
5. Rear view mirror L
6. High / low beam switch
7. Digital speedometer
8. Ignition cum steering lock
9. Master cylinder (front)
10. Rear view mirror R
11. Engine cut off switch
12. Front brake lever
13. Throttle grip
14. Electric starter switch
15. Fuel tank cap



LOCATION OF PARTS - VEHICLE LEFT SIDE

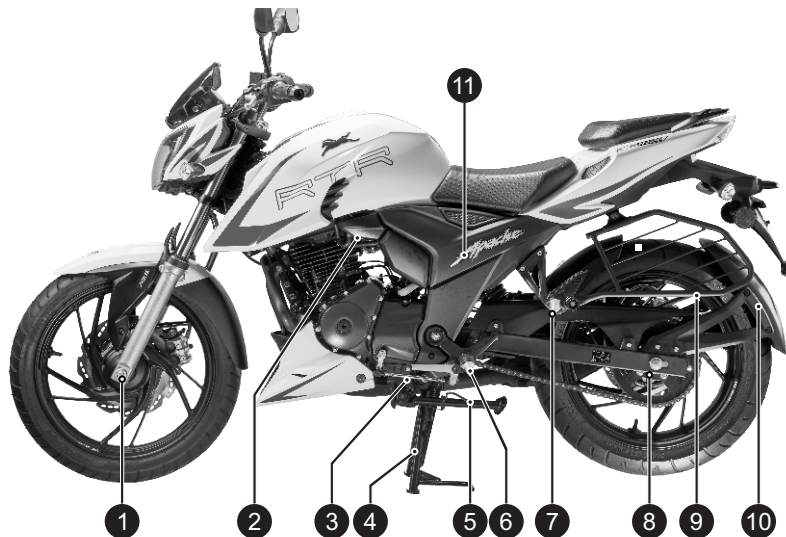

1. Front wheel axle
2. Cover fuel filter EFI
3. Gear shift lever
4. Centre stand
5. Side stand
6. Rider foot rest L
7. Pillion foot rest L
8. Rear wheel axle
9. Saree guard
10. Wheel hugger
11. Cover frame L

LOCATION OF PARTS - VEHICLE RIGHT SIDE

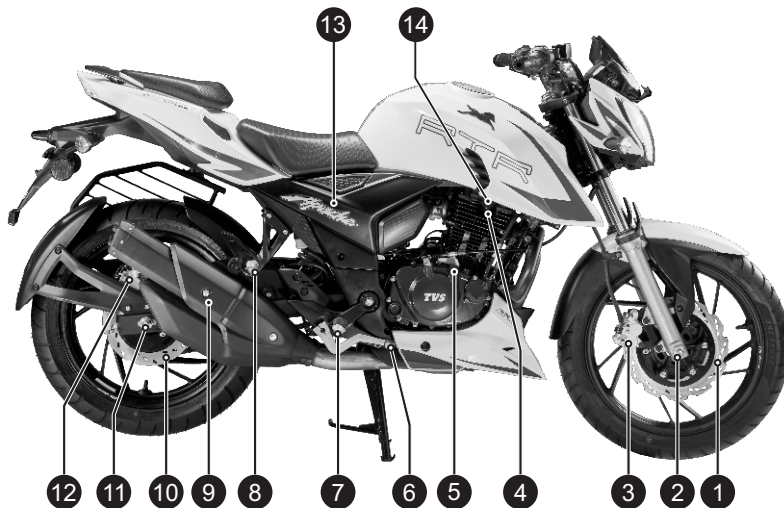

1. Disc plate front
2. Front wheel axle nut
3. Caliper assembly front
4. Spark plug
5. Gauge oil level
6. Rear brake pedal
7. Rider foot rest R
8. Pillion foot rest R
9. Muffler assembly
10. Disc plate rear
11. Rear wheel axle nut
12. Caliper assembly rear
13. Cover frame R
14. Location of ram air duct



LOCATION OF PARTS - VEHICLE FRONT AND REAR

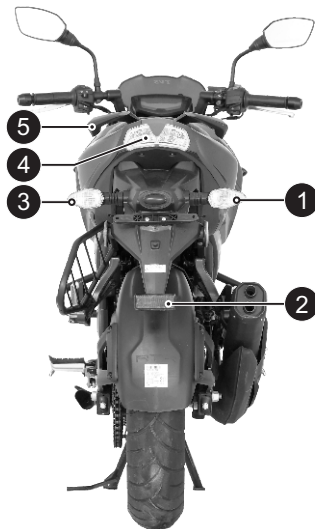
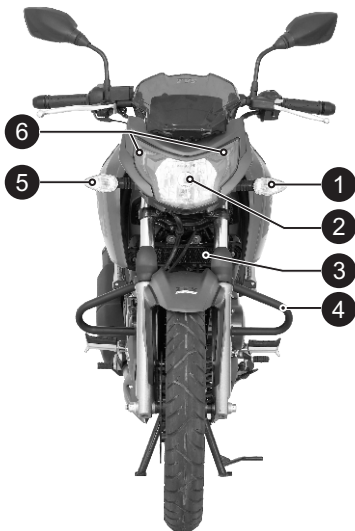

FRONT

1. Turn signal lamp front L
2. Head lamp assembly
3. Oil cooler
4. Crash guard
5. Turn signal lamp front R
6. Position lamps

REAR

1. Turn signal lamp rear R
2. Reflex reflector
3. Turn signal lamp rear L
4. Tail lamp assembly
5. Pillion handle

CONTROL KEY

Your TVS Apache RTR 200 Fi4V with ABS comes with a pair of identical control keys. These keys are to operate ignition cum steering lock, fuel tank cap and seat lock.

IGNITION CUM STEERING LOCK

The ignition switch enables and disables the electrical circuit and steering lock. The three positions of the switch are described below.

1. 'OFF' position

All electrical circuits are deactivated. The key can be removed from the lock.

2. 'ON' position

All electrical circuits are activated. The instrument cluster and warning lights perform the self-diagnostic cycle once upon activation. The engine can be started. The key cannot be taken out from the lock.

Note

When you switch on IGNITION KEY, pump priming noise may be heard, which is normal. Avoid frequent SWITCH-OFF & ON of ignition key, to avoid unnecessary run of fuel pump.



3. 'LOCK' position

Your TVS Apache RTR 200 Fi4V with ABS steering can be locked in both 'left' and 'right' directions.

Turn the handlebar to the extreme 'left' or 'right'. Press the key in and rotate it to the 'LOCK' position from 'OFF' position. All electrical circuits are deactivated and the steering is locked. The key can be removed from the lock.

Insert the key into the lock and turn it to 'OFF' or 'ON' position to unlock the steering.

i Note

Speedometer background illumination and position lamps glow automatically once the ignition key is turned 'ON' without activating other switches.

When the ignition switch is turned 'ON' the speedometer performs self diagnostic cycle. Wait till the message 'RACE ON' appears on the speedo dial.

Please remember that the ABS indicator glows during the self diagnostic cycle of speedometer.

⚠ Warning

Never attempt to move the vehicle when the steering is locked, you may lose balance.

⚠ Caution

Leaving the ignition cum steering lock in 'ON' position for a prolonged time will drain the battery when the vehicle is not in use. Switch OFF and take the key out when the vehicle is not in use.

Always lock the steering while parking for safety.

DIGITAL SPEEDOMETER

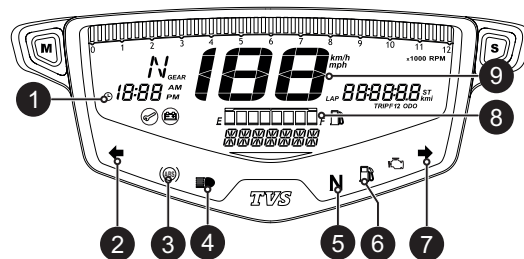

1. Digital clock
Indicates the time in 12 hour time format.



2. Turn signal indicator left (←)
Flashes when the 'left' side turn signal indication is activated.

i Note

If the battery is disconnected and reconnected during service. You may need to reset the time as explained in page no. 28.

3. ABS warning lamp

ABS warning lamp () blinks when the ignition key is turned 'ON' and speedometer performing self check. This lamp goes 'OFF' once the vehicle reaches the speed 10 km/h and above. If this lamp glows continuously then have your vehicle checked at TVS Motor Company Authorised Distributor or Dealer / Authorised Service Center (refer page no. 05 for more details).

4. High beam indicator lamp ()

Glows when the head lamp is activated in high beam.

5. Neutral indicator lamp (N)

Glows when the vehicle is in neutral and goes 'OFF' if the gear is shifted from neutral.

6. Low fuel indication ()

Blinks when the fuel level reaches to minimum safe fuel level. It glows continuously when the fuel comes below minimum safe level.

7. Turn signal indicator right ()

Flashes when the 'right' side turn signal indication is activated.

Caution

Before turning IGNITION key to ON position, ensure availability of adequate fuel in tank. That is LOW FUEL INDICATION shall not come ON, before vehicle starting.

To avoid dry run of fuel pump, never run vehicle beyond 5 kms, after LOW FUEL INDICATION.

8. Fuel gauge

Digital bars indicate the approximate quantity of fuel available in the fuel tank. There are eight bars to indicate the quantity of fuel available in the fuel tank.



All the eight bars will be displayed when the fuel in the tank reaches above 10.5 liters approximately (full tank). When the fuel reaches half tank (6.5 liters approx.) the fuel gauge displays only four bars as shown.



The fuel gauge shows only single bar when the fuel reaches minimum safe fuel level (3.5 liters approx.)



Low fuel indication (serial no. 5) starts blinking and one bar will be visible when the fuel reaches to the minimum safe level 2.5 liters approximately. Refill the fuel immediately. Once the fuel level reaches 1.8 liters approximately, no bar will be visible and low fuel indication (serial no. 5) glows continuously.



If all the fuel level bars in the speedometer are blinking and an error message 'CHECK FUEL SENSOR' scrolls at bottom, Contact nearest TVS Motor Company Authorised Distributor or Dealer / Authorised Service Center.

9. Speedometer

Indicates the vehicle speed in kilometer per hour by default as and when the ignition is turned ON. This can be changed to miles per hour. Change the mode between kilometer per hour and mile per hour using the mode and set switch buttons. (Refer Page no. 28 for changing the speed indication between km/h and mph).



i Note

If you leave the ignition key in 'ON' position and vehicle is kept without moving for more than 3 minutes, an error message 'CHECK SPEED SENSOR' will scrolls which is normal.

If you notice an error message 'CHECK SPEED SENSOR' while the vehicle is in move, Contact nearest TVS Motor Company Authorised Distributor or Dealer / Authorised Service Center for rectification.

10. Odometer / Trip meter 1 & 2 / Lap indicator / High speed indicator / Shortest time indicator

The procedure for setting each mode is given in page 27.

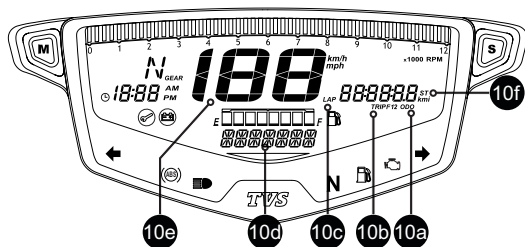

10a. Odometer

Odometer registers the total distance covered by the vehicle in kilometer or mile as per the user's preferred setting. The digit after the dot mark denotes one tenth of a kilometer or mile. Set the meter in 'ODO' mode to know the odometer reading.



10b. Trip meter

In ODO mode, press mode button once and twice to enter 'TRIP 1' and 'TRIP 2' meters respectively.

Trip meter indicates the trip distance travelled in kilometer or mile (as per the preferred settings). The digit after the dot mark denotes one tenth of a kilometer or mile.

Provision to measure two different distance 'TRIP 1' or 'TRIP 2' is provided for the users to use as per their convenience.



10c. Lap timer

Lap timer indicates the time taken to complete the lap. In 'TRIP 2' meter mode, Press mode button once to enter lap timer mode. After speedometer enters lap timer mode, press SET button for more than 1 sec. After set button input, lap timer indicating digit blinks at a rate of 2 Hz.

Lap timer will start counting when the vehicle speed is more than 3 km/h and stops blinking once it starts counting.



Lap timer will stop counting and starts blinking once the vehicle speed reduces to below 3 km/h. Blinking will stop once the vehicle comes to neutral.

New lap can be started once the data is cleared manually (refer page 20 for resetting the lap timer data).

LAP **00:00:00**

i Note

Lap timer works only when the lap timer mode is active.

10d. Alpha numeric display

The self diagnostic alpha numeric display indicates the information about current mode and error messages when the ignition key is turned ON.

10e. High speed indicator

High speed indicator records the maximum speed (top speed) achieved by the rider so far either in km/h or mph as per preferred setting. You can reset and record the new speed if required. Refer page no. 20 for resetting the high speed data.

Set the meter in 'HIGH SPEED' mode to know the maximum speed achieved by any user in this vehicle so far.

Whenever the vehicle speed crosses the previous achieved high speed then speedometer will scroll 'ACHIEVED HIGH SPEED' in display and flash the high speed data at the rate of 2 Hz till the scrolling completes when speed comes less than 3 km/h. This will happen in all modes except shortest time mode.

120 km/h

i Note

Maximum speed recorded so far will be displayed whenever the meter is set in 'HIGH SPEED' mode.

This display will go off automatically once the vehicle starts moving (> 1 km/h) and it will continue the normal operation. Max speed recorded will be stored until manual reset. If the high speed is reset, the speed value will be shown as '0'.

10f. Shortest time indicator

Shortest time indicator records the minimum time taken so far to reach 60 km/h or 40 mph speed (according to the preferred setting).

You can reset and record new time if required. Set the meter in 'SHORTEST TIME' mode to know the time taken by a rider to reach the specific speed from starting.

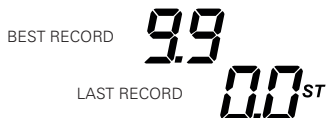

i Note

Minimum time taken recorded so far to reach 60 km/h or 40 mph speed will be displayed when the ignition is turned 'ON' and the meter is set in 'SHORTEST TIME' mode. Once the speed reached 60 km/h or 40 mph, then the time will stop at the exact point.

The best time achieved by any user and the last time taken to reach 60 km/h or 40 mph speed will be displayed in 'SHORTEST TIME' mode as shown below. You can only reset the last time taken and record new time. The 'best record' time will be

automatically replaced by next best time and the new best time recorded will be flashed and 'BEST SHORTEST TIME' scrolls in running display when the vehicle comes less than 3 km/h.

- 11. Shift RPM indicator / 12. Tachometer / 13. Trip F / 14. Gear position indicator / 15. Service reminder / 16. Low battery indicator / 17. Malfunction indicator lamp / 18. Alpha numeric display (Side stand warning)**

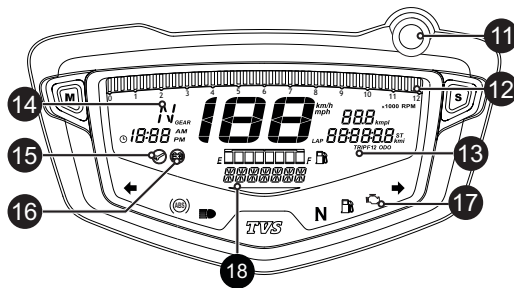

11. Shift RPM indicator

Gear shift RPM indicator alerts the user to shift the gears when engine reaches the specified RPM. Users can set the RPM indication levels as per their riding convenience in multiples of 1000 and from 1000 to 12000 RPM. When the engine reaches the set RPM, red indicator in the digital speedometer glows and indicates the user to shift to next higher gear.

i Note

Shift RPM indicator does not work when the vehicle is in neutral or when the fifth gear is engaged.

12. Tachometer

Tachometer indicates the engine speed in multiples of 1000 RPM (Revolutions Per Minute).

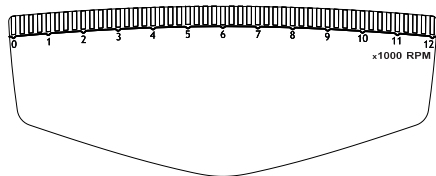

13. Trip F

This function shows the distance travelled after the low fuel indication symbol (⛽) starts blinking and fuel gauge shows no segment bar, the display automatically switches to the 'TRIP F' indicator after 1km or 0.6 miles as per preferred settings and 'TRIP F' meter starts counting from 1 km in km/h mode and 0.6 miles in mph mode.



If the fuel level remains in minimum safe level, the reading is saved even after the ignition key is turned 'OFF'.

The count stops and clears automatically after a certain distance covered when the fuel level rises above minimum safe level. 'TRIP F' meter cannot be activated or deactivated manually.

The speedometer will be in TripF mode for a distance of 1km even after filling the petrol to 1 bar level.

At every ignition ON, 'TRIP F' meter will get enabled automatically until fuel level is reached above minimum safe level (2.5 L / 1 bar indication).

14. Gear position indicator

The gear position indicator in the digital display indicates the position of the gears.



15. Service reminder

If the vehicle is due for service, whenever the ignition lock is turned 'ON', an icon with spanner symbol  blinks for 10 seconds after the speedometer's self diagnostic cycle and continues to glow till the vehicle is serviced and reset. Get the vehicle serviced at TVS Motor Company Authorised Distributor or Dealer / Authorised Service Center.

 Note

If you notice an error message 'CHECK GEAR SENSOR', Contact nearest TVS Motor Company Authorised Distributor or Dealer / Authorised Service Center for rectification.

Service reminder indicator lamp works only based on the distance (km/miles) covered by the vehicle. This is only a reminder indicator. Customers are advised to keep track and follow the service schedule.

16. Low battery indicator

An icon with battery symbol  ' glows when the battery charge is too low. Get the battery checked at TVS Motor Company Authorised Distributor or Dealer / Authorised Service Center.

17. Malfunction indicator lamp

MIL is turned ON when the ECU detects a fault in the system.

If malfunction indicator lamp  ' glows immediately contact nearest TVS Motor Company Authorised Distributor or Dealer / Authorised Service Center.

Ignition	Engine	Malfunction indicator	Status
On	Off	On	Ok
On	On	Off	Ok
On	On	On	Fault



18. Alpha numeric display (Side stand warning)

If side stand is ON, then speedometer will scroll 'SIDE STAND ON' in display.

i Note

The vehicle will start in side stand in neutral gear but it will not in other gears. The vehicle will also 'switch off' if the side stand is ON and gear is changed from neutral to gear.

Incase of any errors in side stand switch, then speedometer will scroll 'CHECK SIDE STAND' in display.

In the event of any unfortunate accident, if the side stand / side stand switch has been damaged, the signal can be bypassed by disconnecting the side stand switch coupler. Upon detection of Side stand switch, vehicle start function is enabled in all the gears and not switched off when changed from neutral to gear. It is customer responsibility to verify the position of side stand manually until it is fixed.

MODE AND SET BUTTONS

Sequence of mode is as follows:

1. ODO
2. Trip 1
3. Trip 2
4. Lap timer
5. High Speed
6. Shortest time mode

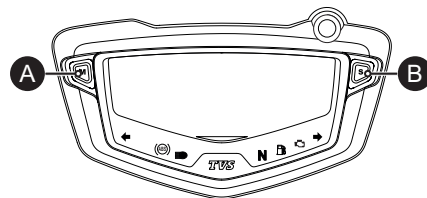





The mode (A) and set (B) buttons are provided to change the mode between 'ODO', 'TRIP 1', 'TRIP 2', 'LAP timer', 'HIGH SPEED', 'SHORTEST TIME' and to set the MPH, CLOCK, GEAR SHIFT RPM etc.

Setting the digital display

Every press of the mode button changes the display to other mode. Follow the below procedures to change the display to desired mode.

If ignition is turned OFF when the meter is in ODO or TRIP meters, then the respective meters will be displayed in the next ignition ON. If any other modes other than these were set during ignition OFF, then ODO meter will be displayed in the next ignition ON.

1. In ODO mode, press the mode button twice or thrice to change display to '  ' or '  ' mode.
 - To reset any of the trip meter while ensuring the display is in 'TRIP 1' or 'TRIP 2', press and hold the set button for a few seconds
2. Press the 'Mode' button till the 'LAP  ' timer display appears to set the 'LAP' timer mode.
 - The Lap timing achieved by any user will not be stored and will be deleted once the mode is changed or ignition is turned 'OFF'.
3. Press the 'Mode' button till the '  ' display appears to set the 'HIGH SPEED' indicator mode.
 - To reset the high speed recorded, keep the display in 'HIGH SPEED' mode and press the 'Set' button for a few seconds.

i Note

Mode and set buttons will not work when the vehicle speed exceeds above 10 km/h or 6 mph in the respective modes.

4. Press the 'Mode' button till the display changes to 'BEST RECORD  ' to set the 'SHORTEST TIME' indicator.
 - To reset the 'LAST RECORD' of the shortest time, press and hold the 'Set' button for few a seconds. Please remember only current record will be reset and best time display will remain same.
5. Press the 'Mode' button once to change the display to ODO mode again.

KMPH and MPH setting

- Ensure the display is in 'ODO' mode.
- Press and hold the 'Mode' button till 'MPH' blinks in display. Press 'Set' button to select the 'MPH' mode, the 'MPH mode' icon scrolls in running display for one full cycle.
- To change the display to 'KMPH' mode again, press and hold the 'Mode' button till 'KMPH' blinks in display. Press 'Set' button to select the 'KMPH' mode, the 'KMPH mode' icon scrolls in running display for one full cycle.

Digital clock setting

- Press and hold the 'Mode' button till 'MPH' icon blinks in display.
- Release and press the 'Mode' button once again so that the 'Clock' icon blinks.



- On pressing the 'Set' button, 'CLOCK MODE' scrolls in running display and the hour digit of the clock blinks.
- Now, press the 'Mode' button to increase the hours while hour digits are blinking.
- On pressing the 'Set' button again the hours of the clock is set and the minute digit blinks.
- Now, press the 'Mode' button to increase the minutes while minute digits are blinking.
- Else, on pressing the 'Set' button again the minutes of the clock is set and the hour format 'AM' or 'PM' blinks.
- Press the 'Mode' button to change the hour format 'AM' or 'PM'.
- Press the 'Set' button once again to set hour format and to come out from clock setting.

Setting the Shift RPM

- Press and hold the 'Mode' button till 'MPH' icon blinks in display.
- Release and press the 'Mode' button twice so that the 'RPM' icon blinks.
- Press the 'Set' button to reach shift RPM setting mode the 'SHIFT RPM' icon scrolls in running display for one cycle. Previous RPM setting value is displayed in the bar display and LED will glow.

- Now, press the 'Mode' button to increase the RPM (multiples of 1000) in cyclic fashion. Once the user starts updating, the LED stops glowing.
- Pressing the 'Set' button exits the setting. Once the shift RPM is set, the LED again glows till this mode is exit.

Note

By default the shift rpm is set to 7000 RPM. You can set it to your convenience as per your riding habit.

COOLING SYSTEM

TVS Apache RTR 200 Fi4V with ABS is designed with an external oil cooler with stone guard arrangement for optimal engine cooling.

The oil cooler is mounted in front of the engine which improves the engine durability and provides better heat management without any compromising the engine performance.

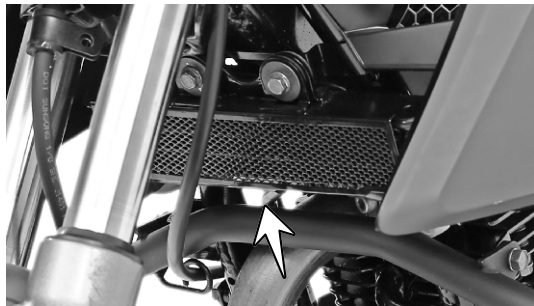

RAM AIR DUCT

TVS Apache RTR 200 Fi4V with ABS is designed with a ram air duct on the right side of the fuel tank. This ram air duct throws air exactly above the spark plug while the vehicle is in motion.

The air thrown above the spark plug cools the plug and maintains its temperature in optimum level. Which in-turn results in better heat management without any compromise on the engine performance and improves the engine's durability.

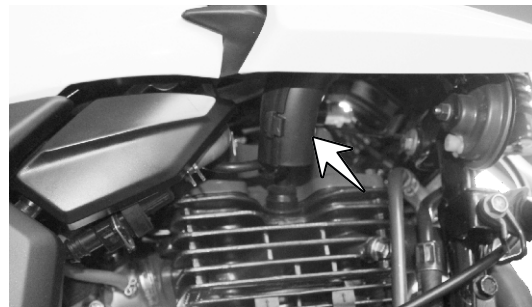

Caution

Care should be taken not to block the ram air duct air passage by cover or any other means. Else it will lead to over heating of engine or seizure.





HANDLE BAR LEFT SIDE

1. Horn switch

Press the switch () to blow horn. It is used to attract the attention of other road users in case of danger.

2. Turn signal lamp switch

When the turn signal switch is moved to left '  ' or right '  ', the corresponding turn signal lamps flashes. To stop flashing, push the switch in.

3. Clutch lever

Press the lever towards grip to disengage the drive. It is used to disengage the clutch while shifting the gears.

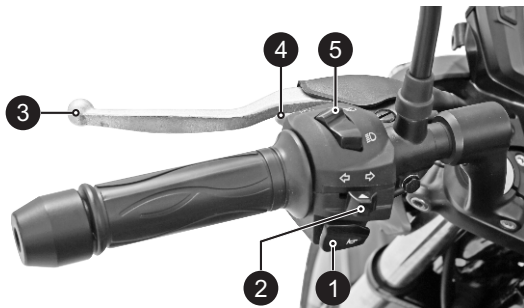

4. Pass-by switch

Press the switch to flash the head lamp. It is used to give signal to the vehicles coming from the opposite direction while overtaking other vehicles during day.



If the pass by switch is pressed when the engine is in OFF condition, the head lamp HIGH beam alone will glow with 50% of intensity.

Once the engine is started, the head lamp glows automatically and the head lamp beam toggles between HIGH beam to LOW beam or vice versa on pressing the switch.

Pass by system will not work if the engine cut off switch is turned 'OFF'.

5. Head lamp high / low beam switch

The head lamp glows automatically once the engine is started. Only the head lamp beam (high/low) can be controlled with the beam control switch.

Press the top end of switch for HIGH beam '  ' and bottom end for LOW beam '  '.

Warning

Failure to switch the turn signal lamp ON or OFF at the right time may lead to an accident.

⚠ Warning

Use appropriate head lamp beam 'high / low' as per the traffic and road conditions for your safety and to avoid inconvenience to other riders.

It is strongly recommended to ride the vehicle in 'low beam' during day.

i Note

Once the engine is started the head lamp glows automatically. Only head lamp beam (high/low) can be controlled using beam control switch.

Head lamp intensity will reduce by 50% if the engine is kept idle for more than 20 sec (approx).

Pass by system will not work if the engine cut off switch is turned 'OFF'.

HANDLE BAR RIGHT SIDE

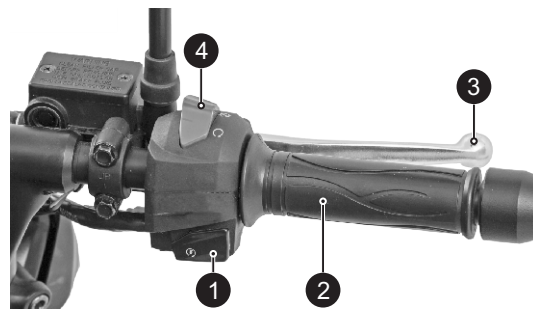

1. Electric starter switch

Ensure the transmission is in neutral or else press the clutch lever before engaging the electric starter switch '⚡'. Release the electric starter switch after the engine has started.

If the electric starter switch is pressed more than 3 seconds continuously, the starter motor gets disabled automatically and will not crank the engine. The motor cranks the engine only after 3 seconds or if the switch is released and repressed again.



i Note

Before starting, ensure to turn ON the engine cut off switch.

Release the electric starter switch immediately after the engine has started.



3. Throttle grip

It controls the fuel-air mixture supplied to the engine, which regulates the engine speed. Rotate the throttle grip in counter-clockwise from its idle position to increase the engine speed and vice-versa to reduce.

3. Front brake lever

It controls a hydraulic circuit that operates the front braking system. The front brake is applied by pressing the front brake lever gently towards the grip. The brake lamp glows on application of front brake.

4. Engine cut off switch

It is used to switch off '  ' the engine but to keep other DC system active. The ignition circuit is disabled, preventing the engine from being restarted. To restart the engine, return the switch to the '  ' position.

FUEL TANK* CAP

Flush type fuel tank cap (1) is provided in TVS Apache RTR 200 Fi4V with ABS. To open the fuel tank cap, lift the protection lid (2), insert the control key into the lock and turn it in clockwise and lift the cap. Press the cap back to close. Rotate the key anti-clockwise, take out the key and close the lid.

To avoid accumulation of water in the fuel tank, a small drain hole and a pipe is provided in the fuel tank lid cavity so that the water entering through the lid is drained out through a hose.



** The fuel tank is not a measuring instrument and the capacity of the fuel tank may slightly vary from the indicated capacity.*

Warning

Do not smoke while refueling. Do not use cell phones while refueling. Avoid spilling of fuel on the hot engine. Refill petrol in well ventilated area. Switch off the engine while refueling as petrol is highly inflammable. After refilling close the cap properly.

EVAPORATIVE EMISSION CONTROL SYSTEM

This vehicle is fitted with Evaporative Emission Control System (EVAP). If there is any abnormal jerk, startability issue are felt in the vehicle or noise due to sudden escape of gas during opening of fuel tank cap, immediately report to the TVS Motor Company Authorised Distributor or Dealer / Authorised Service Center.

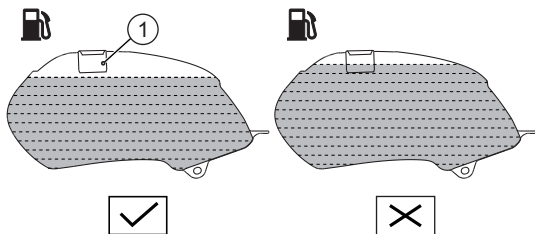

Caution

Never fill fuel beyond the fuel tank inlet (1). Filling above the inlet may result in improper breathing of fuel tank which leads to difficulty in starting as well as improper running of the vehicle. Whenever refueling the bike fill only the recommended quantity of fuel (10 liters including 2 liters reserve).

Do not clean the vehicle by laying down on floor, to avoid fuel entry into EVAP system.

GEAR SHIFT LEVER

TVS Apache RTR 200 Fi4V with ABS is equipped with a 5 speed constant mesh transmission.

Neutral (N) position of the transmission is indicated by the warning light on the speedometer.

To shift the transmission from neutral to first gear, push the gear shift lever down.

To change it to the second gear, lift the lever up. Lifting the lever up repeatedly engages all the gears in succession up to the fifth gear.

The gear shift indicator on the speedometer dial indicates the current gear position.

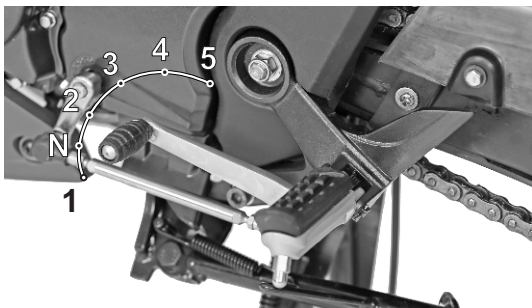

i Note

Gear shift lever position can be set to your convenience. Contact your TVS Motor Company Authorised Distributor or Dealer / Authorised Service Center for setting the gear shift lever position.

! Caution

Never shift gears without disengaging the clutch and releasing the throttle. Failure to comply this will lead to rough shift or jerk while shifting the gears. Remember to return to neutral position before restarting the engine.

REAR BRAKE PEDAL

The rear brake pedal is located adjacent to the right foot rest. To control speed of your vehicle close the throttle completely, and gradually press the brake pedal down wards.



i Note

Rear brake pedal position can be set to your convenience. Contact your TVS Motor Company Authorised Distributor or Dealer / Authorised Service Center for setting the brake pedal position.

! Caution

Independent use of rear or front brake reduces the overall braking efficiency. In extreme conditions braking with only rear or front brake may lock the wheel which would result in skidding or toppling of vehicle.

Braking performance is affected adversely with wet surfaces, loose surfaces and overheating of brake system due to unnecessary continuous application of brakes. For safety, exercise extreme caution while braking and also at turning. Do not accelerate while turning.

STANDS

TVS Apache RTR 200 Fi4V with ABS is equipped with a centre (1) and side stand (2). To place the vehicle on the centre stand, hold the handle bar left grip with left hand and pillion handle with right hand.

Place your foot firmly on the centre stand extension (1a) and press with adequate effort. Ensure both the legs of centre stand are touching the ground before placing the vehicle on the stand.

Side stand can be operated by sitting on the vehicle with your left foot by pushing it away from the vehicle to its extreme end.

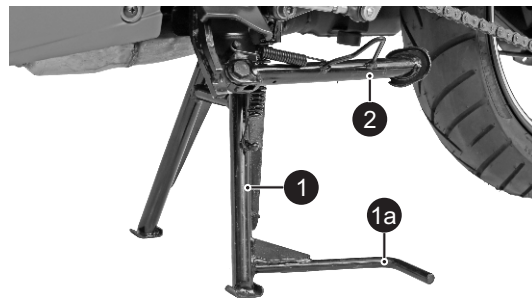
**! Caution**

Do not sit on the vehicle when it is parked on the side stand / centre stand, as your full weight would rest on the vehicle's only support.

! Warning

Park the motorcycle safely on a solid ground. On slopes, engage the first gear and park the vehicle in such a way that the front wheel faces uphill.

Always release the side stand to its full up position before moving the vehicle.

SEAT

The seat lock is located between the rider and the passenger seat assembly.

Rear seat (passenger seat)

To remove the rear seat (1), insert the ignition key into the seat lock (2). Turn it clockwise, pull & release the front section of the seat first, followed by the rear section as shown in the above figure. To install the rear seat, reverse the removal procedure.

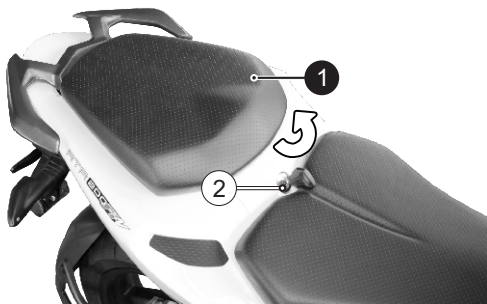

Caution

Make sure that the seat is locked securely in position.

Utility box is located under the passenger seat to store some important items and it provides security to things placed inside.

Front seat (rider seat)

To remove the front seat (3), remove the rear seat (passenger seat) and take out the key from the lock. Take out the utility box by gently dislocating it from seat release cable (A).

Pull the seat release cable (A) to release seat lock. Keeping the seat release cable pulled, lift the seat from rear end & slide it backward to remove.

To install the front seat, reverse the removal procedure.

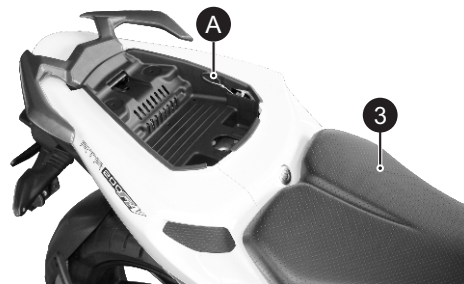

TOOL KIT

To assist you in performing certain aspects of periodic maintenance and emergency repairs, a tool kit is supplied along with the vehicle.

Tool kit is located under the passenger seat. To access the tool kit, remove the passenger seat as explained in page no. 28.

Tool kit consists of one number each of the following.

1. Grip driver
2. Bit (+) (-)
3. 10 x 12 open end spanner
4. 14 x 17 open end spanner
5. 16 box spanner
6. Tool bag



Warning

Do not remove the tool kit from the vehicle. Always ensure to keep them along with the vehicle.

Note

Keep the tool kit only in the designated location locked with band to avoid falling-off or creating noise

Caution

It is recommended to use the tool kit in case of any emergency only. It is always advisable to take your vehicle to TVS Motor Company Authorised Distributor or Dealer / Authorised Service Center.

COVER FRAME R

Removal

Cover frame R is provided to access the battery and rear disc brake master cylinder. This cover can be opened in the following manner:

1. Remove the seats as explained in Page no. 28.
2. Remove the mounting screws (1), (2), (3) and take out the cover frame.





Re-install

Locate the lugs of the cover frame at the holes provided on the frame and install the mounting screws (1), (2) and (3).

Caution

Make sure that the cover frame is locked securely in position after installation.

SMART PHONE CHARGERS (optional)*

An all new smart phone charging port has been provided under the rider's seat assembly of your vehicle. Remove the rider's seat assembly as explained in page no. 28.

Please follow the guidelines provided for using it properly:

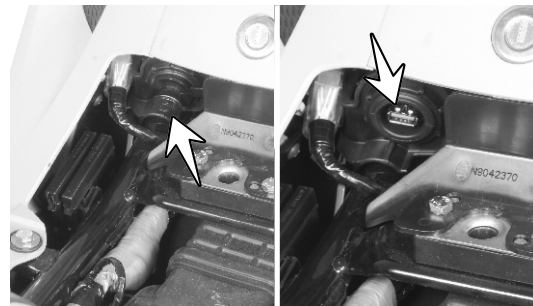

DO'S

1. Ensure that no water enters into the unit, by closing the USB flap properly.
2. Use only mobile phone company's authorized USB cable for mobile charging.

3. Ensure the flap is not damaged while opening / inserting the USB cable.

DON'T'S

1. Do not leave the USB charging flap open/partially closed when not in use.
2. Do not attempt to use/charge any other device, other than one mobile phone at a given time.
3. Do not try to force the USB connector in, check if it is inserted in the appropriate direction, to prevent damage.
4. Do not charge your mobile when engine is off.
5. Do not use other device, this port is for charging mobile phones only.

The charging time of the mobile may vary, depending on the mobile battery's state of charge.

The flap in the unit has been designed to prevent water entry and is not replaceable. No warranty in case of cover flap cut.



Caution

TVS is not responsible for any damage to mobile phones in the event of fall while charging during vehicle moving.

INSPECTION BEFORE RIDING

Check the following items before riding.

ITEM	WHAT TO CHECK FOR
Engine cum transmission oil	Availability of oil upto the level (page no. 47)
Fuel	Enough fuel for the planned distance of running
Tyres	Correct pressure (page no. 52) Adequate tread depth / No cracks or cuts
Battery	Proper working of all lamps, horn and pass by switch. Low battery indication Battery voltage (page no. 44)
Speedometer	Performing self-check
Steering	Smooth movement / No play or looseness
Throttle	Correct free play of cable / Smooth operation
Clutch	Correct free play of cable (page no. 48) / Smooth and progressive action
Brakes	Availability of brake fluid and proper working of brake (page no. 50)
Wheels	Free rotation
Drive chain	Slackness and lubrication of chain (page no. 54)

STARTING THE ENGINE

As you turn the ignition switch to the 'ON' position, the instrument cluster and the warning lights will go through the self-diagnostic cycle. During this phase, make sure that all the warning lights on the cluster comes on.

The following conditions must be verified before starting the engine.

- ❑ The engine cut off switch is in 'O' position.
- ❑ The gear is in neutral.
- ❑ If gears are engaged, the clutch lever is pulled.

Press the start button without applying the throttle. As soon as the engine starts, release the start button.

Caution

Do not keep the engine in idling rpm for long and do not open excessive throttle when the vehicle is parked. It leads to overheating of engine and damage to the internal components.

The engine will not start if the throttle is opened full. If the engine fails to start after repeated attempts, engine would have flooded with petrol.

To clear flooding, follow the below procedure.

1. Open the throttle fully.
2. Press the start button for 5 to 6 seconds and close the throttle.
3. Follow starting procedure to start the engine as mentioned above.
4. If engine starts, slightly open the throttle to stabilize idle.
5. If the engine does not start, wait some time and repeat the above procedure 1 to 4.

SETTING THE VEHICLE IN MOTION

1. Depress the clutch lever and engage first gear by pressing the gearshift lever down.
2. Open the throttle slowly and simultaneously, release the clutch lever gently and gradually. The vehicle starts moving forward.
3. As the vehicle picks up speed, shift to the next higher gear by closing the throttle, applying the clutch and lifting the gear shift lever up.
4. Release the clutch lever and open the throttle smoothly. Select the required gears in a similar manner.



Using the transmission

The transmission is provided to keep the engine to run smoothly in its normal operating speed range.

The gear ratios have been carefully chosen to meet the characteristics of the engine.

The rider should always select the most suitable gear to achieve the necessary speed and pulling power smoothly.

Riding on hills/gradients

When climbing steep hills, the motorcycle may begin to slow down and show lack of power. At this point the rider should shift to a lower gear so that the engine will again be operating in its normal power range. Shift gears rapidly to prevent the motorcycle from losing momentum.

When riding down a hill, the engine may be used as brake by shifting to a lower gear.

Warning

Reduce speed to a safe limit before turning/cornering. Do not apply brake while turning/cornering. Do not disengage clutch before braking.

STOPPING AND PARKING

1. Close the throttle completely and apply both the brakes simultaneously.
2. Down shift the gears with clutch lever pressed / disengaged as the road speed decreases. Bring the engine to neutral position just before the vehicle stops.
3. Turn the ignition 'OFF'.
4. Park the vehicle on a firm, flat surface.
5. Lock the steering.

Warning

Since the engine and exhaust system becomes very hot, make sure to park the vehicle in a place where pedestrians or children are not likely to touch the hot surface.

Do not park near dry grass or any other flammable resources which might catch fire.

To avoid deterioration of paint gloss due to ultra violet rays and heat of sunlight, always park your motorcycle in a covered parking.

FUEL RECOMMENDATION

Use unleaded petrol only.

The petrol should be 85 to 95 octane by research method. Use recommended fuel additives for longer life of engine components and lower maintenance. Petrol mixed with ethanol will have impact on engine components. Contact your TVS Motor Company Authorised Distributor or Dealer / Authorised Service Center for usage.

Caution

Never mix oil and petrol in the fuel tank. Always fill fuel from reputed and reliable fuel stations.

CHECKS AND TIPS FOR IMPROVING FUEL ECONOMY

Regular checks

Carry out the periodic maintenance checks as specified in this manual (refer page no. 40 to 42).

Regular maintenance checks will save fuel ensuring trouble-free, enjoyable and safe riding besides keeping the environment clean .

Spark plug

A dirty or defective spark plug leads to wastage of fuel due to incomplete combustion. Inspect and clean the spark plug if necessary. Visually inspect the spark plug gap. If the gap is found more replace the plug with a new one.

However the spark plug need to be replaced every 12000 kms (1 year). Always use recommended spark plug only.

Air cleaner element

A dirty air cleaner element restricts airflow and increases fuel consumption. Replace the element every 12000 kms.

Since paper filter is used in your motorcycle, it is not advised to clean the filter. Replace the filter in case of any abnormalities.

Clutch

Increase in engine rpm during acceleration, without increase in road speed indicates clutch slip. A slipping clutch will cause high fuel consumption and overheating of engine.

If the condition persists even after adjusting the clutch lever play, immediately have the clutch checked by TVS Motor Company Authorised Distributor or Dealer



/ Authorised Service Center.

Caution

Never drive the vehicle with the clutch lever pressed. This will reduce the life of clutch and affect the vehicle performance and fuel economy.

Engine cum transmission oil

Dirty or less engine cum transmission oil increases the friction between various parts of the engine and reduces the engine life, thereby increases fuel consumption.

Regularly inspect the engine cum transmission oil for correct level and top-up if necessary. Get it replaced at regular intervals as per the maintenance schedule. Always use TVS TRU4 FULLY SYNTHETIC oil only (SAE 10W 30 API-SL, JASO Ma2) or recommended equivalent oil.

Fuel leak

If any fuel leak is suspected, tow the vehicle to the nearest TVS Motor Company Authorised Distributor or Dealer / Authorised Service Center and get it corrected.

Caution

Do not attempt to do any rectification, as fuel lines are normally pressurized upto 3.5 bar and any activity by any untrained personnel, may lead to un-safe condition.

Evaporation

Vehicle parked in the hot sun leads to wastage of fuel through evaporation. Also, lower fuel levels in the tank will have increased evaporation and condensation of moisture inside, which will result in rusting of the tank. Ensure to close fuel tank cap after every filling. If the fuel tank cap is kept open for a long time, it leads to loss of fuel and safety.

Tyres

Low tyre pressure has adverse effects on the vehicle. The drag on the vehicle increases resulting decreased fuel economy. Further more, handling may be affected adversely.

Check the tyre pressure regularly (weekly) and inflate them to the recommended pressure (refer page no. 52). Never use tyres which are worn out beyond the permissible limit.

Chain slackness

Check and ensure drive chain slackness. Excess slackness leads to higher fuel consumption (refer page no. 54).

Wheels free movement

Check and ensure the free movement of wheels by rotating the them at least once in a week to avoid wastage of fuel.

Fast starting from rest wastes fuel

A racing start from rest at full throttle will waste fuel and damage the engine. It also creates a potentially dangerous traffic situation.

Fast acceleration wastes fuel

Fuel is wasted whenever the rider suddenly accelerate or apply brake.

Avoid unnecessary idling

While waiting for someone or stopping in signals for long time, if the engine is kept running at idle speed, it causes unnecessary wastage of fuel.

Avoid frequent braking

Anticipate corners and slopes as well as the traffic conditions. Unnecessary and frequent braking reduces the fuel economy.

Note

The on-road mileage of TVS Apache RTR 200 Fi4V with ABS is dependent on several factors like Road condition, Quality of fuel, Riding speed, operation of Clutch and Brake, Tyre inflation, Maintenance / timely servicing of vehicle, load etc.. and hence will differ from the mileage given under standard test conditions.

MAINTENANCE SCHEDULE

The maintenance schedule indicates the intervals between periodic services. At the end of each interval, be sure to inspect, check, replace, adjust, lubricate and service as instructed. If the maintenance is not done periodically, it will result in rapid wear and severe damage to the vehicle. If the vehicle is used under high stress conditions such as continuous full throttle operation or is operated in dusty area, certain jobs should be performed more often to ensure reliability of the vehicle. Cylinder head, steering components, suspension, chain and wheel components etc., are key items and require very special and careful servicing. TVS Motor Company Limited strongly recommends that the jobs as per the maintenance schedule be performed by your TVS Motor Company Authorised Distributor or Dealer / Authorised Service Center.

Periodic inspections may reveal one or more parts that may need replacement. Whenever replacing parts on TVS Apache RTR 200 Fi4V with ABS, it is recommended that you use only the TVS Motor Company Genuine parts.

Caution

Proper running-in and maintenance are mandatory for making certain that your vehicle is reliable and gives optimum performance at all times. Make sure that the periodic maintenance is performed thoroughly in accordance with the instructions given in this owner's manual.

In more dusty areas, the air filter element required early replacement than the mentioned kilometers to avoid costly damages to the engine.

PERIODIC MAINTENANCE SCHEDULE (months or km whichever occurs earlier)

Item	Service km Period from the date of sale	Service						Remarks	
		1st 500-750 1 month	2nd 2500-3000 3 months	3rd 5000-6000 6 months	4th 8500-9000 9 months	5th 11500-12000 12 months	Every 3000 km		Every 6000 km
Engine cum transmission oil		R	I&T	R	I&T	R	I&T	R	
Oil filter (strainer)		C	-	C	-	C	-	C	
Oil filter (paper filter)		R	-	R	-	R	-	R	
Spark plug		I & C	-	-	-	R	-	-	Replace every 12000 km
Air cleaner element		-	-	-	-	R	-	-	Replace every 12000 km
Tappet clearance		I & A	-	I & A	-	I & A	-	I & A	
Fuel filter		-	-	-	-	-	-	-	Replace every 20000 km
Oil cooler fins		-	-	I & C	I & C	I & C	I & C	-	
Oil cooler pipes		-	I	I	I	I	I	-	Inspect & replace if required every 15000 km
Clutch plates		-	-	-	-	-	-	-	Inspect & replace if required every 21000 km
Engine breather hose		I	I	I	I	I	I	-	Replace every 21000 km if required
Hose fuel		I	I	I	I	I	I	-	Replace every two years or 20000 km
Clutch and throttle cable play ¹		I, A & L	I, A & L	I, A & L	I, A & L	I, A & L	I, A & L	-	
Throttle grip		-	-	L	-	L	-	L	Lubricate using grease

¹ Inspect for proper operation and adjust play. Lubricate ends using grease.

Contd...



Item	Service km Period from the date of sale	Service						Remarks	
		1st 500-750 1 month	2nd 2500-3000 3 months	3rd 5000-6000 6 months	4th 8500-9000 9 months	5th 11500-12000 12 months	Every 3000 km		Every 6000 km
Steering smooth operation/play ²	I & A	–	–	–	–	C, L & A	–	–	C & L with fresh Bechem premium grade 3 grease every 12000 km
Front fork oil	–	–	–	–	–	–	–	–	Replace every 18000 km
Front and rear suspension ³	I	I	I	I	I	I	I	–	
All fasteners	I & TI	I & TI	I & TI	I & TI	I & TI	I & TI	I & TI	–	Tighten if necessary
Drive chain**	C, L & A	C, L & A	C, L & A	C, L & A	C, L & A	C, L & A	C, L & A	–	Adjust if necessary
Retainer oil seal ⁴	I	I	I	R	I	I	I	–	Replace every 9000 km
Chain guide bottom ⁵	I	I	I	R	I	I	I	–	Replace every 9000 km
All bulbs, horn and switches	I	I	I	I	I	I	I	–	Inspect for proper functioning
Head lamp beam	I & A	I & A	I & A	I & A	I & A	I & A	I & A	–	
Specific gravity and voltage ⁶	I	I	I	I	I	I	I	–	
Brake effectiveness	I	I	I	I	I	I	I	–	

² Inspect for smooth steering rotation, steering shake / noise. Adjust the steering if necessary.

³ Inspect for smooth and proper function of front and rear suspension. Also inspect for any visual damage and oil leakage.

^{4&5} Inspect at every service. Replace if found damaged. However the retainer oil seal & the chain guide bottom need to be replaced every 9000 km.

⁶ Recharge if necessary

** Clean the drive chain with dry cloth and apply TRU SPRAY / TRU 4 oil as frequently as every 500 km for better chain life and smooth vehicle running.

Contd...

Item Service km Period from the date of sale	Service							Remarks
	1st 500-750 1 month	2nd 2500-3000 3 months	3rd 5000-6000 6 months	4th 8500-9000 9 months	5th 11500-12000 12 months	Every 3000 km	Every 6000 km	
Brake pedal shaft	L	L	L	L	L		–	Lubricate using TRU4 oil
Brake pad wear	I	I	I	I	I	I	–	Replace if necessary
Brake fluid	I & T	I & T	I & T	I & T	I & T	I & T	–	
WSS / toner ring	I & C	I & C	I & C	I & C	I & C	I & C	–	Replace if damaged
WSS cable clamps - (front & rear)	I	I	I	I	I	I	–	Fix new clamp if found missing
WSS cable	I	I	I	I	I	I	–	Replace if damage
Brake hose/bundy tubes	I	I	I	I	I	–	I	Replace every 30000 km
Bundy tube mounting (all joints)	I & TI	I & TI	I & TI	I & TI	I & TI	I & TI	–	Inspect for leak
HECU mounting cushions	–	–	I	–	I	–	I	Replace every 30000 km
Toner rings teeth damage	I	I	I	I	I	I	–	Replace if necessary
Malfunction codes	I	I	I	I	I	I	–	
Master cylinder cups	–	–	–	–	–	–	–	Replace every 21000 km
Wheel freeness	I	I	I	I	I	I	–	
Tyre pressure at cold condition	I & S	I & S	I & S	I & S	I & S	I & S	–	
Engine idling RPM	I	I	I	I	I	I	–	
Idling CO%	I	–	–	–	–	–	–	I every 12000 km
Ball joint gear shift lever	–	–	L	–	L	–	L	Lubricate using grease
Centre / side stand pivot	L	L	L	L	L	L	–	Lubricate using TRU4 oil

Contd...



Item	Service km	Service						Remarks	
		1st 500-750 1 month	2nd 2500-3000 3 months	3rd 5000-6000 6 months	4th 8500-9000 9 months	5th 11500-12000 12 months	Every 3000 km		Every 6000 km
Swing arm bearings		–	–	–	–	–	–	–	C & L with fresh Bechem premium grade 3 grease every two years
Wheel balancing ⁷		–	–	–	–		–	–	
Evaporative emission control system									Check for intactness of hoses and canister
Fuel tank assembly**		I & C	I & C	I & C	I & C	I & C	I & C	I & C	

R - Replace; I - Inspect; T - Top up; C - Clean; A - Adjust; L - Lubricate; TI - Tighten; S - Set

⁷ Wheel balancing to be done every 1 year or every 12000 km. In addition, after every tyre puncture repair or tyre replacement, wheel balancing to be done.

**Check for abnormal vehicle jerk / noise while opening the cap / leak. If found any, contact TVS Motor Company Authorised Main Dealer or Authorised Dealer.

RECOMMENDED LUBRICANTS

Application	Qty	Manufacturer	Brand
Engine cum transmission oil	1200 ml (during servicing) 1400 ml (during engine overhaul)	TVS Motor Company	TVS TRU4 FULLY SYNTHETIC oil (SAE 10W30 API-SL, JASO Ma2) or recommended equivalent oil
Front fork oil	325 ± 2 cc		KYB G10 oil
Disk brake fluid	–	–	DOT 3 / DOT 4
Grease	–	Bechem	Bechem premium grade 3
Chain lubricant	–	TVS Motor Company	TRU SPRAY
Fuel additives	As recommended		IFTEX



SELF - MAINTENANCE PROCEDURES BATTERY

Battery is located below the cover frame R. TVS Apache RTR 200 Fi4V with ABS is fitted with a maintenance free battery. so it is not required to fill the distilled water.

To ensure better performance and long from the battery, you are requested to follow the steps given below:

1. Park the vehicle using the centre stand on a firm and flat surface.
2. Remove the cover frame R (refer page no. 30).
3. Check the battery voltage in every service and charge if the battery voltage is less than 12.4V

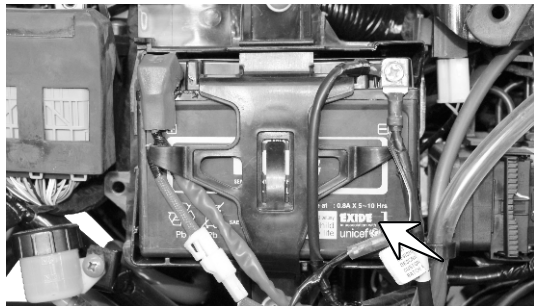

charge the battery using MF battery charger only at TVS MOTOR COMPANY Authorised Distributor or Dealer / Authorised Service Centers.

4. Do not add additional electrical accessories.
5. While connecting the terminals, observe the correct polarity. Connect the red wire to the ' + ' positive terminal and black wire to the ' - ' negative terminal of the battery.
6. Apply petroleum jelly at terminals to prevent it from corrosion.

Incase of any abnormality or for removal of battery from the vehicle, contact TVS Motor Company Authorised Distributor or Dealer / Authorised Service Center.

Caution

Never check the battery charge by shorting the terminals. Always connect the positive terminal first (red wire) and then negative (black wire) to avoid sparking.

If the motorcycle is to remain unused for a long time (a month or longer), it is advisable to disconnect the battery cables or have the battery removed by skilled personnel.

FUSE REPLACEMENT

Non-working of electrical systems may be due to safety fuse failure. Short circuit or overload in the electrical system are the main causes for fuse failure.

Follow the procedure given below for inspecting and replacing the fuse.

1. Turn 'OFF' the Ignition.
2. The fuse case is fitted under the rider's seat contains 4 fuses.
 - ❑ 10A fuse - EFI loads
 - ❑ 15A fuse - Other electrical systems
 - ❑ 20A fuse - Battery
 - ❑ 25A fuse - ABS

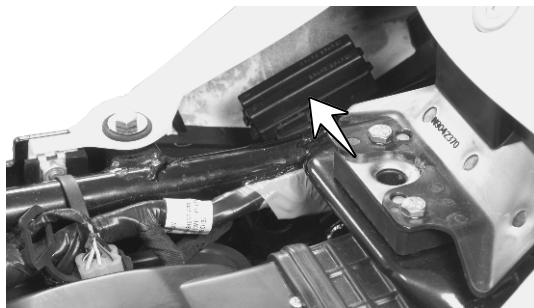

Good Fuse

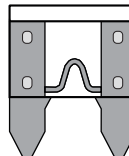

Blown Fuse

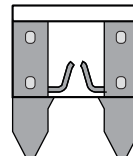

Remove the seats and utility box (refer page no. 28) to access the fuse case.

3. Remove the fuse case.
4. Open the fuse case and pull out the blown fuse.
5. Replace the blown fuse with a new (extra fuse is provided inside the fuse case itself).
6. Close and refit the fuse case back to its position.
7. Turn 'ON' the ignition lock and check for proper functioning of the electrical systems. In case the fuse fails again, consult the nearest TVS Motor Company Authorised Distributor or Dealer / Authorised Service Center.

Caution

Do not use vehicle by **shorting the wires without a fuse**. This may result in overheating of electrical / wiring and may result in fire. Never replace a fuse with a rating other than that prescribed, in order to avoid damage to the electrical equipment.

SPARK PLUG

1. Wipe and clean the dust and mud around the spark plug mounting to avoid their entry inside the cylinder.
2. Pullout the suppressor cap from spark plug. Remove the spark plug using a plug spanner.

A spark plug with heavy carbon deposits will not produce strong sparks. Hence, only if necessary, remove the carbon deposits from the spark plug with a small wire brush or spark plug cleaning tool.

Inspect the spark plug electrodes (A) and (B) for any corrosion. If found any replace the spark plug with a new one.

Visually inspect the spark plug gap. The gap should be 0.8 to 0.9 mm. If the gap is found to be more than the limit replace the spark plug with a new one.

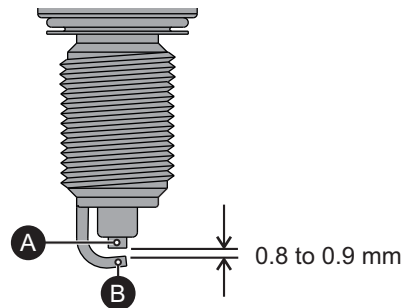

After cleaning and inspecting the gap, reinstall the spark plug and tighten by hand to avoid cross threading. Finally tighten using the spanner. Do not over tight or cross thread the spark plug.

Caution

Always use only recommended make and type of spark plug. **Replace spark plug every 12000 km.**

Don't remove the spark plug when the engine is hot. Cover the spark plug hole with a cloth when the plug is removed to prevent entry of dust / water.

Caution

It is advisable to tighten the new spark plug by hand till the end, using plug spanner tighten by 1/4 turn. Then loosen the plug by 1/8 turn and re-tighten using plug spanner.

Care should be taken not to damage the spark plug cooling duct (ram air duct) during dismantling / assembling the spark plug.

ENGINE CUM TRANSMISSION OIL

Check the engine cum transmission oil level periodically. The gauge oil level is provided at the right-hand side crankcase cover.



1. The check must be performed when engine is in cold condition, after placing the motorcycle in center stand with front wheel touching the ground.
2. Place the motorcycle in an upright position on a horizontal and firm surface.
3. Wipe-off the surroundings of gauge oil level.
4. Remove the gauge oil level and wipe it clean.
5. Re-insert the gauge oil level by completely screwing it in.
6. Once again remove the gauge and check the oil level.
7. The oil level should be between the minimum and maximum level marks on the gauge as shown in the figure.
8. If the oil level is below the minimum level, top up with TVS TRU4 FULLY SYNTHETIC oil (SAE 10W 30 API-SL, JASO MA2) or recommended equivalent oil upto the maximum level mark. Do not overfill.
9. Wipe out the oil traces with a clean cloth to prevent dust accumulation and re-fix the gauge.

Warning

Correctly recycle or dispose the used engine oil in order to avoid environmental pollution.

Caution

Do not run the vehicle with insufficient / without engine cum transmission oil as it will cause serious damage to the engine components.

Excessive oil filling will cause oil leak and other malfunctions. Always use TVS TRU4 FULLY SYNTHETIC oil only (SAE 10W30 API-SL, JASO Ma2).

Make sure that no foreign object gets in the crankcase while topping up the engine oil.

CLUTCH ADJUSTMENT

Clutch lever free play is one of the most important adjustment which you may need to check in-between services for better life of the clutch plates.

The free play of the clutch lever should be 8 ~ 13 mm as measured at the clutch lever end at handle bar.

Adjust the clutch lever free play periodically by means of clutch cable adjuster at arm clutch release. If the free play is not within the specified limit.

1. Ensure that the engine is cold (engine oil at room temperature).
2. Loosen the lock nut (2) while holding the clutch cable adjuster (3).

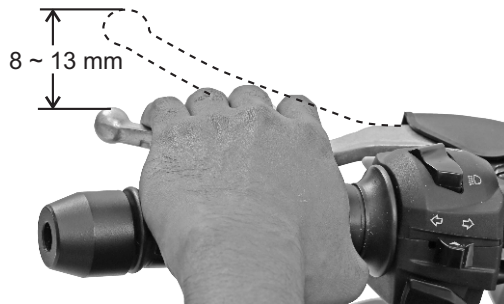

3. Adjust the clutch cable adjusting nut (1) 'in' or 'out' to give sufficient play in the clutch lever.
4. After adjusting the play, hold the adjuster nut in the same position, tighten the lock nut.

Caution

Too much or too less clutch lever free play will damage the clutch plates, thereby affecting the performance of the vehicle.

Clutch lever free play should be adjusted only when the engine is cold.

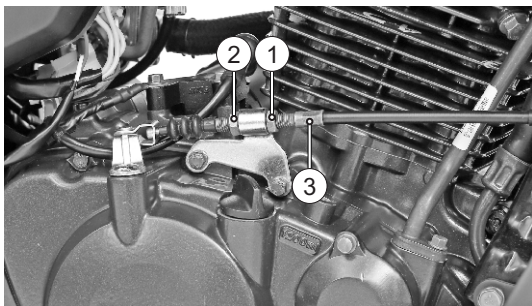

REAR SHOCK ABSORBER

TVS Apache RTR 200 Fi4V with ABS is provided with dual rated, 7 step adjustable, gas filled rear shock absorber to meet different road and load.

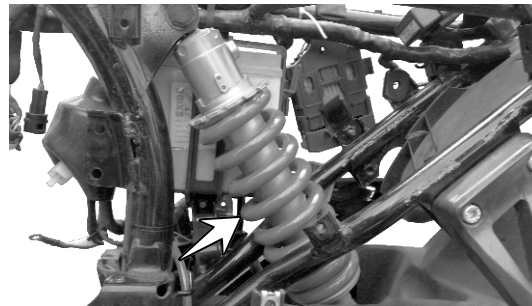

Caution

After adjusting free play properly, if there is a clutch slip or there is difficulty in shifting gear, visit your TVS Motor Company Authorised Distributor or Dealer / Authorised Service Center for rectification .

Warning

The rear shock absorber contains highly compressed gas. Do not try to open or disassemble it in any way.

Caution

Adjust step by step. Do not go at a stretch as it will damage the cam.

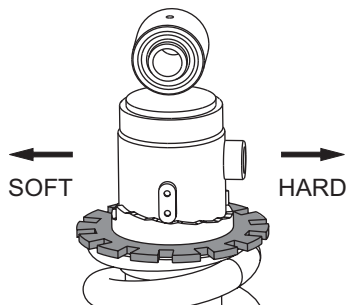

i Note

During the time of delivery of the motorcycle, the rear suspension is adjusted to the standard configuration.

Rear shock absorber spring stiffness can be set to your convenience. Contact your TVS Motor Company Authorised Distributor or Dealer / Authorised Service Center for setting the rear shock absorber load.

BRAKES

Front brake

You can observe a master cylinder (1) on the right side of the handle bar, a caliper assembly (2) fitted to the fork leg R along with a wheel speed sensor (3), a disc (4) to the front wheel and and toner ring (5) to the front wheel. Also you can observe a high pressure hose connecting the master cylinder to the HECU of ABS and another hose connecting HECU to the caliper assembly.

1. Check the master cylinder brake fluid level through the view piece glass (A).

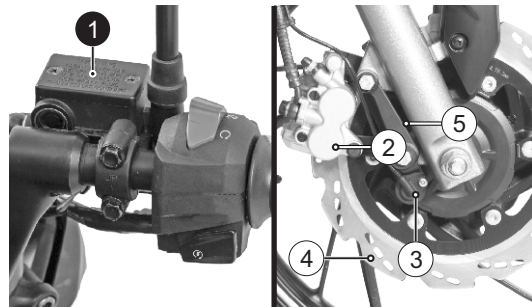

2. Brake fluid level always should be above the 'LOWER' mark (B) provided on the master cylinder when the master cylinder is parallel to the ground.
3. If the brake fluid level is below the mark or while applying brake if you feel the brake is more spongy or ineffective due to air entry, contact TVS Motor Company Authorised Distributor or Dealer / Authorised Service Center for topping-up the brake fluid, air bleeding and other brake related inspections.

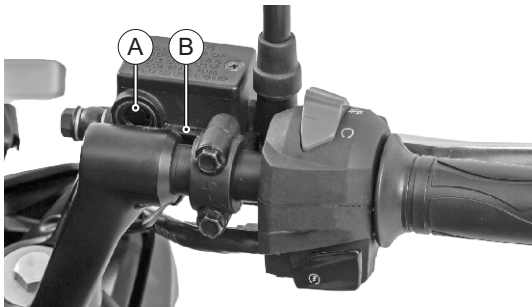

i Note

Check the brake fluid level only when the master cylinder is parallel to the ground.

Rear brake

You can observe a master cylinder (1) mounted on the right side rider foot rest, a reservoir (2) below the cover frame R, a caliper assembly (3) fitted on the rear wheel axle along with wheel speed sensor (4), a disc (5) and toner ring (6) to the rear wheel. Two high pressure hoses connecting the master cylinder to HECU and HECU to the caliper.

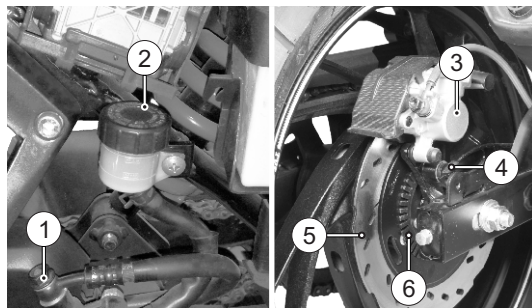

1. Remove the cover frame R (refer page no. 31 for removal procedure).
2. Check the brake fluid level in the reservoir. It should be between maximum and minimum level.
3. If the brake fluid level is below minimum or while applying brake if you feel the brake is more spongy or ineffective due to air entry, contact TVS Motor Company Authorised Distributor or Dealer / Authorised Service Center for topping-up the brake fluid, air bleeding and other brake related inspections.



Warning

Lack of maintenance of the brake system increases the risk of accident. If you notice any malfunction in brake system contact nearest TVS Motor Company Authorised Distributor or Dealer / Authorised Service Center.

Brake pad wear indicator

Visually check the brake pads for wear. If the wear is found beyond the wear indicator groove as shown in the figure then, replace the brake pads as a set with a new one.

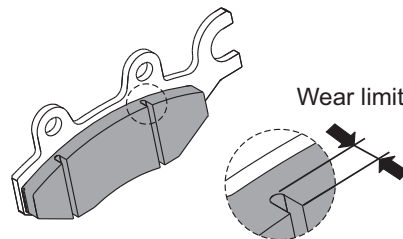

Caution

Replace the brake pads as a set, if the wear indicator shows beyond the wear limit.

TYRES

Tyre pressure:

Check the tyre pressure atleast once in a week if not more frequently. Insufficient air pressure in the tyres not only hasten tyre wear, but also seriously affects the stability of the vehicle.

Under-inflated tyres make smooth cornering difficult and over-inflated tyres decreases the tyre contact with the ground which can lead to skidding and loss of control. Be sure that the tyre pressure is within the specified limits at all times.

	Solo	Pillion
Front	1.75 kg/cm ² (25 PSI)	1.75 kg/cm ² (25 PSI)
Rear	2.00 kg/cm ² (28 PSI)	2.25 kg/cm ² (32 PSI)

Tyre tread condition

Operating the vehicle with excessively worn tyres will decrease riding stability and can lead to loss of control. It is recommended to replace the tyre when the tyre wears off to the tyre wear indicator level (indicated by TWI on the tyre).

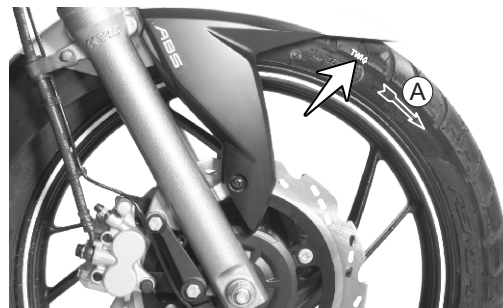

Tyre rotation direction

While reassembling the tyre, after removing from wheel rim, ensure that the arrow mark (A) provided on the tyre, faces the direction of wheel rotation.

Warning

The tyre inflation pressure in cold condition and the tyre thread condition are extremely important for the performance and safety of the rider. Check the tyres frequently for inflation pressure as well as the wear pattern on it. Use of a tyre other than the standard will cause instability.

Tyre puncture

TVS Apache RTR 200 Fi4V with ABS is fitted with a tubeless tyre on both front and rear wheel. In case of any puncture / tyre damage it is advised to visit nearest tyre manufacturer Dealer or the tyre repair shops who know the repairing methods of tubeless tyres.

It is not necessary to remove the tyre from wheel rim always to attend the puncture. Eventhough, if there is a need of tyre removal, it is strongly recommended to use a tyre removal / fitment machine. If at all, tyre levers need to be used, the levers should be free from sharp edges and care should be taken not to damage the rim and tyre.

Caution

Side walls of the tubeless tyres which are in contact with the wheel rim are only seals the air inside the wheel assembly. Hence, care should be taken not to damage the side walls of the tyres during removal / reassembly.

Wheel balancing to be done every 1 year or every 12000 km. In addition, after every tyre puncture repair or tyre replacement, wheel balancing to be done.

Warning

Use of a tyre other than the standard may cause instability and improper function of ABS.

Keep the toner ring upwards whenever the wheel is removed in order to avoid damage to the toner ring. Damaged toner ring affects the ABS function.

DRIVE CHAIN

Proper lubrication and adjustment of drive chain gives long service life of the chain. Poor maintenance of the chain causes premature wear or damage to the drive chain and sprockets. The drive chain must be cleaned, checked, lubricated and adjusted at specified intervals mentioned in the maintenance schedule.

Even though the chain is cleaned, lubricated and adjusted during regular service by the Dealers, the user must clean the chain with a dry cloth and apply TRU SPRAY / TRU4 oil as frequently as every 500 km for better chain life and smooth vehicle running.

Check, clean, lubricate and adjust the drive chain in the following manner:

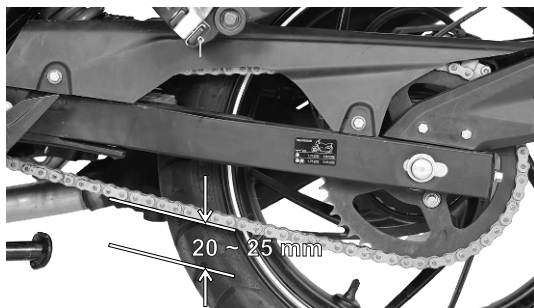

1. Place the vehicle on centre stand with the transmission in neutral.
2. Inspect the drive chain slackness (vertical movement) using the finger as shown in the figure.
3. The slackness of the drive chain should not exceed the limit (20 ~ 25 mm).
4. If the slackness is found more contact TVS Motor Company Authorised Distributor or Dealer / Authorised Service Center for adjustment.
5. If the slackness is found within the limit, clean the chain with a dry cloth and lubricate using TRU SPRAY/TRU4 oil.

Caution

Lubricate the drive chain after the motorcycle is washed with water or riding in rainy/ wet condition.

The chain must be serviced more frequently when the vehicle is operated under severe conditions like dusty, muddy, wet, high speed or frequent starting / stopping.

Misalignment of rear wheel or sprockets can cause abnormal wear of chain and sprockets and results in unsafe riding condition.

Warning

Riding with improperly adjusted chain / high slackness can cause the chain to come off the sprockets resulting in accident or serious damage to the motorcycle.

FRONT WHEEL REMOVAL AND REASSEMBLY

1. Remove the axle nut (1) along with a washer.
2. Pull out the axle (2) along with a washer and remove a spacer from both the sides of the wheel.
3. Place a support below the frame to prevent vehicle from falling and lift the vehicle up.
4. Carefully dislocate the disc from the caliper assembly and slide the wheel out.
5. Reverse the procedure for reassembling.

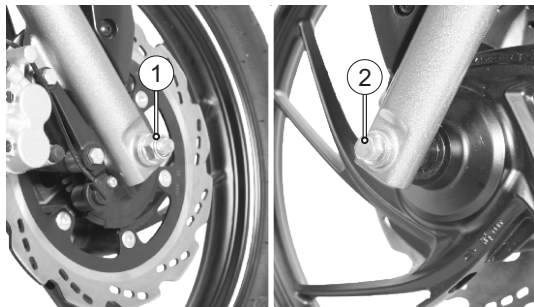

Warning

Ensure proper seating of disc in the caliper assembly while reassembling the wheel.

REAR WHEEL REMOVAL AND REASSEMBLY

1. Remove the wheel hugger rear.
2. Remove the axle nut (1) and along with the washer and partially pull out the axle (2).
3. Take out the caliper assembly by dislocating it from the disc and the swing arm lug.
4. Carefully hang the caliper assembly in the swing arm itself. Take out the spacer and pull out the axle fully.
5. Remove the wheel assembly by gently tapping it along with the disc.
6. During re-assembly, engage the drum sprocket with the wheel along with the drive chain and then assemble the wheel into swing arm.

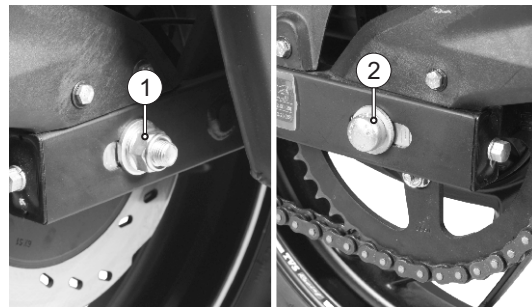

7. Re-assemble the other parts in the reverse order of removal.

Caution

While assembling the caliper assembly ensure that the slot provided in the caliper is properly located to the lug provided in the swing arm assembly.

Always make sure that whenever the wheel is removed, axle nut is properly re-tightened to the specified torque and chain play is re checked and adjusted if required.

Note

During removal of rear wheel axle hold the drum sprocket assembly with the hand as it may fall. Carefully hang the drum sprocket along with chain in the swing arm itself.

Warning

Keep the toner ring upwards whenever the wheel is removed in order to avoid damages to the toner ring. Damaged toner ring affects ABS function.

STORAGE PROCEDURES

For storage of your motorcycle for longer periods of over a month and above, we recommend to carry out the following steps:

1. Clean the vehicle thoroughly. Park the vehicle on centre stand.
2. Warm up the engine and drain engine cum transmission oil. Store the oil, if new, in a dust free container.
3. Remove the spark plug and feed in several drop of engine cum transmission oil through spark plug hole. Crank the engine few times and reinstall the spark plug.
4. Remove the battery, store it away from direct sunlight and freezing temperatures.

Caution

Do not park the vehicle on a slope or soft ground or else it may fall.

During storage, the battery must be recharged on a constant current battery charger at recommended amperage atleast once in a month.

5. Place a suitable support at the bottom of the frame so that both the tyres are off the ground. This will ensure better tyre life.
6. Cover up the vehicle completely with a clean tarpaulin or any other suitable cover. Store the vehicle inside a garage or similar area to avoid damage due to dust and rain. Make sure that the storage area is well ventilated and free from any source of flame or spark.



Caution

Do not switch ON the ignition without filling petrol to a minimum safe level (as given in page no.13) to avoid fuel pump dry run and to avoid fuel pump damage.

Avoid using alkaline solution like detergent soaps for washing. This may damage head lamp and other lamp assemblies.

TAKING THE VEHICLE OUT OF STORAGE FOR REGULAR USE

1. Take the vehicle out of the garage and clean it thoroughly.
2. Remount the battery after bench charging if required.
3. Fill the engine cum transmission oil (TVS TRU4 FULLY SYNTHETIC - SAE 10W30 API-SL, JASO Ma2) or recommended equivalent oil and check the oil level using the gauge.
4. Lubricate the parts as instructed in the maintenance schedule.
5. Fill up petrol in the fuel tank.
6. Check and inflate the tyres to the specified tyre pressure.
7. Check and correct the points mentioned in page no.33.

RECOMMENDED TIPS WHEN TAKING A LONG TRIP OF MORE THAN 500 KM

- A) Please keep the following items for use in case of emergency:
1. Complete tool kit / first aid kit
 2. Recommended spark plug one number.
 3. Head lamp and turn signal lamp bulbs one number each.

4. Throttle and clutch cables one number each.
- B) Precautions to be taken for the journey:
 1. Ensure engine cum transmission oil and brake oil level are up to the level.
 2. Adequate fuel in fuel tank.
- C) Check your motorcycle for the following:
 1. Tightness of all bolts and nuts with correct torque value.
 2. Fitness of tyres / tyre pressure / tread depth.
 3. All bulbs, indicators and horn function.
 4. Balancing of wheel
 5. Check proper functioning of ABS (through ABS warning lamp)
 6. Smooth functioning of all cables and their free plays.
 7. Smoothness of steering operation.
 8. Slackness and lubrication of chain (page no. 54)
 9. Front / rear brake functioning and rear brake lamp switch adjustment.
 10. Front fork for any abnormality.
 11. Any leakage in fuel lines and fuel filter.
 12. Spark plug cleanliness and condition of spark plug.
 13. Air filter element cleanliness.
 14. Lubrication of all items mentioned in the periodic maintenance schedule.
 15. Intactness of EVAP system hoses and canister.
 16. Any other job as necessary.
 17. Have your vehicle checked at any TVS Motor Company Authorised Distributor or Dealer / Authorised Service Center.



Caution

Long journey are to be taken only after the running-in period of 1000 km.



SERVICE RECORD

S.No.	Description	Odometer reading	Job card no. / Date	Servicing Dealer's stamp and sign.
1	1st service between (a) 500 - 750 km or (b) 1 month from the date of purchase, whichever of the two occurs earlier.			
2	2nd service between (a) 2500 - 3000 km or (b) 3 months from the date of purchase, whichever of the two occurs earlier.			
3	3rd service between (a) 5000 - 6000 km or (b) 6 months from the date of purchase, whichever of the two occurs earlier.			
4	4th service between (a) 8500 - 9000 km or (b) 9 months from the date of purchase, whichever of the two occurs earlier.			

SERVICE RECORD

S.No.	Description	Odometer reading	Job card no. / Date	Servicing Dealer's stamp and sign.
5	5th service between (a) 11500 - 12000 km or (b) 12 months from the date of purchase, whichever of the two occurs earlier.			
6	6th service between (a) 14500 - 15000 km or (b) 15 months from the date of purchase, whichever of the two occurs earlier.			
7	7th service between (a) 17500 - 18000 km or (b) 18 months from the date of purchase, whichever of the two occurs earlier.			
8	8th service between (a) 20500 - 21000 km or (b) 21 months from the date of purchase, whichever of the two occurs earlier.			

SERVICE RECORD

S.No.	Description	Odometer reading	Job card no. / Date	Servicing Dealer's stamp and sign.
9	9th service between (a) 23500 - 24000 km or (b) 24 months from the date of purchase, whichever of the two occurs earlier.			
10	10th service between (a) 26500 - 27000 km or (b) 27 months from the date of purchase, whichever of the two occurs earlier.			
11	11th service between (a) 29500 - 30000 km or (b) 30 months from the date of purchase, whichever of the two occurs earlier.			

MANUFACTURER : TVS MOTOR COMPANY LIMITED
P.B. No1, Bythahalli, Kadakola post, Mysore - 571 311, India.

ENGINE

Type : 4 stroke, Oil cooled, single cylinder OHC, EFI
Cylinder bore : 66 mm
Stroke : 57.8 mm
Piston displacement : 197.75 cc
Compression ratio : 9.7 : 1
Air filter : Viscous Paper filter
Oil filter : Wire mesh and micronic paper filter
Lubrication system : Forced wet sump
Maximum power in kW : 13.7 @ 8500 rpm
Maximum torque in Nm : 16.96 Nm @ 6500 rpm
Maximum speed : 128 km / h
Engine idling rpm* : 1550 ± 100 rpm
Starting system : Electric starter

TRANSMISSION

Clutch : Wet - multiplate type
Gear shift pattern : 1 down and 4 up
Primary transmission : Helical gears
Secondary transmission : Chain and sprockets

GEAR RATIOS

I gear : 2.917
II gear : 1.857
III gear : 1.333
IV gear : 1.050
V gear : 0.880
Primary reduction : 2.818
Final reduction : 3.461

* Under warm condition



CHASSIS

Overall length	:	2070 mm
Overall width	:	790 mm
Overall height	:	1080 mm
Seat height	:	800 mm
Ground clearance	:	180 mm
Wheel base	:	1353 mm
Kerb weight (with toolkit and 90% of fuel)	:	153.5 kg
Pay load	:	130 kg
Maximum laden weight	:	283.5 kg
Steering angle	:	34°
Caster angle	:	25.5°
Frame	:	Double Cradle Split Synchro STIFF (DCSSS)
Front suspension	:	Telescopic oil damped
Rear suspension	:	Gas charged Mono shock absorber, 7 step adjustable with rectangular swing arm
Trail length	:	95.5 mm

TYRE***Tyre size**

Front	:	90/90 x 17 Tubeless
Rear	:	130/70 x 17 Tubeless

Tyre pressure

Front	:	1.75 kg/cm ² (25 PSI)
Rear - solo	:	2.00 kg/cm ² (28 PSI)
Rear - dual	:	2.25 kg/cm ² (32 PSI)

BRAKES

Front	:	Hand operated, 270 mm petal disc
Rear	:	Foot operated, 240 mm petal disc

ELECTRICAL

Type	:	AC generator
Ignition system	:	ECU -3D Ignition timing map
Spark plug	:	BOSCH - UR4KE
Battery type	:	12V, 8 Ah MF

* The pneumatic tyres fitted in this vehicle meet the requirements specified by BIS and comply with the requirements under the Central Motor Vehicles Rules (CMVR), 1989.

ELECTRICAL

Generator	: Fly wheel magneto 12V, 260W
Head lamp	: 12V, 60/55W H4
Position lamp	: LED lamp (2W)
Tail / brake lamp	: LED indicators (1W max. / 2.5W max.)
Turn signal lamp	: 12V, 10W x 4
Number plate lamp	: 12V, 2W LED
Instrument panel	: LCD / LED indicators
Horn	: 12V, DC x 2
Fuse	: 12V 25A x 1, 12V 20A x 1, 12V 15A x 1, 12V 10A x 1

CAPACITIES

Fuel tank capacity	: 12 litres (including reserve)**
Reserve	: 2.5 litres
Engine cum transmission oil grade	: TVS TRU4 FULLY SYNTHETIC oil (SAE 10W30 API-SL, JASO Ma2) or recommended equivalent oil
Engine cum transmission oil and capacity	: 1200 ml (during servicing) 1400ml (during engine overhaul)
Front fork oil grade	: KYB G10 oil
Front fork oil capacity	: 325 ± 2 cc
Brake fluid	: TVS Girling DOT 3 / DOT 4

Caution

Using the bulb other than the specified rating can result in overloading of the electrical system or premature failure of the bulb.

Note

Specifications are subject to change without notice.

** The fuel tank is not a measuring instrument and the capacity of fuel tank may slightly vary from the indicated capacity.